

Eaton's Walterscheid™ Metric Tube Fitting Systems

# System Trilogy

Tube connections for all hydraulic systems



**EATON**

*Powering Business Worldwide*



# Eaton's Walterscheid Trilogy

- Simple assembly with pre-fabricated tube ends
- Best-in-class performance
- Maximum system stability and safety
- Superior quality
- Guardian Seal™ corrosion protection
- Global availability
- Available in carbon steel and stainless steel (1.4571)

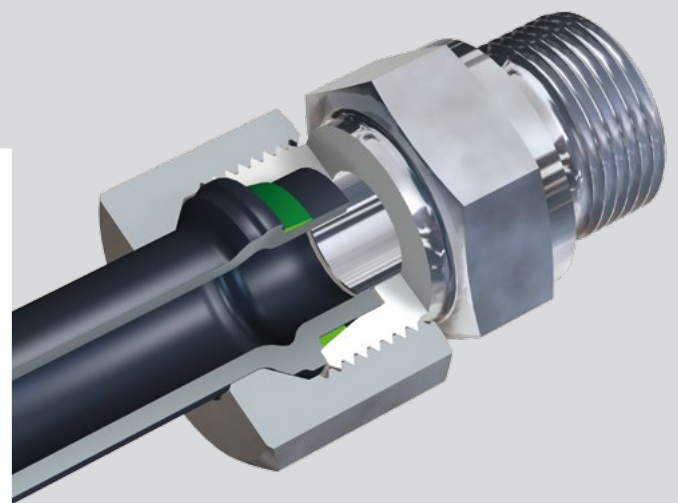
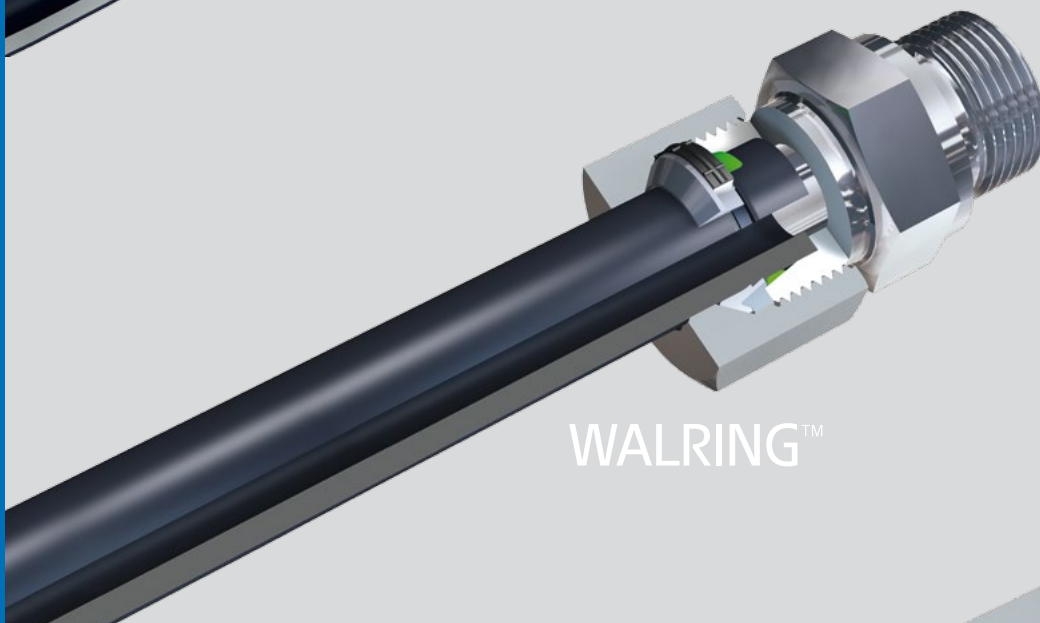

## Performance

- All parts built to DIN EN ISO 8434-1 for 24° fittings
- Available in 6-42 mm tube diameters
- Unsurpassed pressure resistance
- L Series up to 500 bar/7,250 psi
- S Series up to 800 bar/11,600 psi
- 4:1 Safety factor
- Resistance against red corrosion up to 720 hours according to VDMA 24576/K5



## WALPRO™

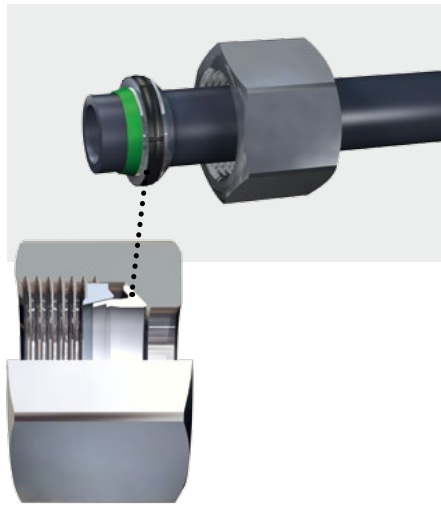

## WALRING™

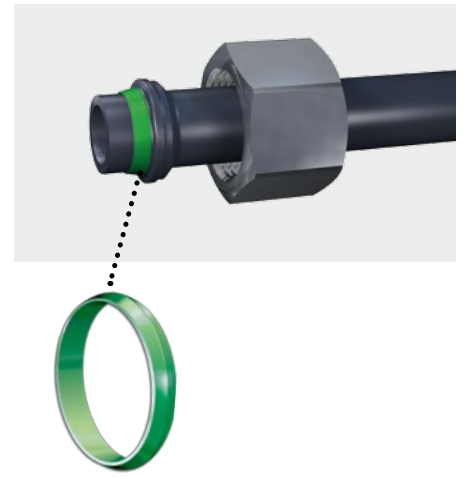

## WALFORMplus™

### Technology

Two-edge cutting ring (profile ring), controlled final assembly

Two-edge cutting ring with captive seal, machine assembly

Cold reshaping of the tube end with captive seal

### System features

Force closure, combined sealing and retaining functions

Force closure, separate sealing and retaining functions

Form closure, separate sealing and retaining functions

### Sealing principle

Metal-on-metal

Elastomeric + Metal-on-metal

Elastomeric + Metal-on-metal

### Prefabrication

Assembly machine

Assembly machine

Reshaping machine

### Tightening travel for final in service assembly

30°–60° after controlled final assembly

30°–60° after machine assembly

Up to the point of resistance

### Torque reduction

≈ 25% compared to manual assembly

≈ 25% compared to manual assembly of a cutting ring

> 25% compared to manual assembly of a cutting ring

### Risk of assembly related failures

Minimal with controlled final assembly machine

Minimal with machine pre-assembly

Minimal

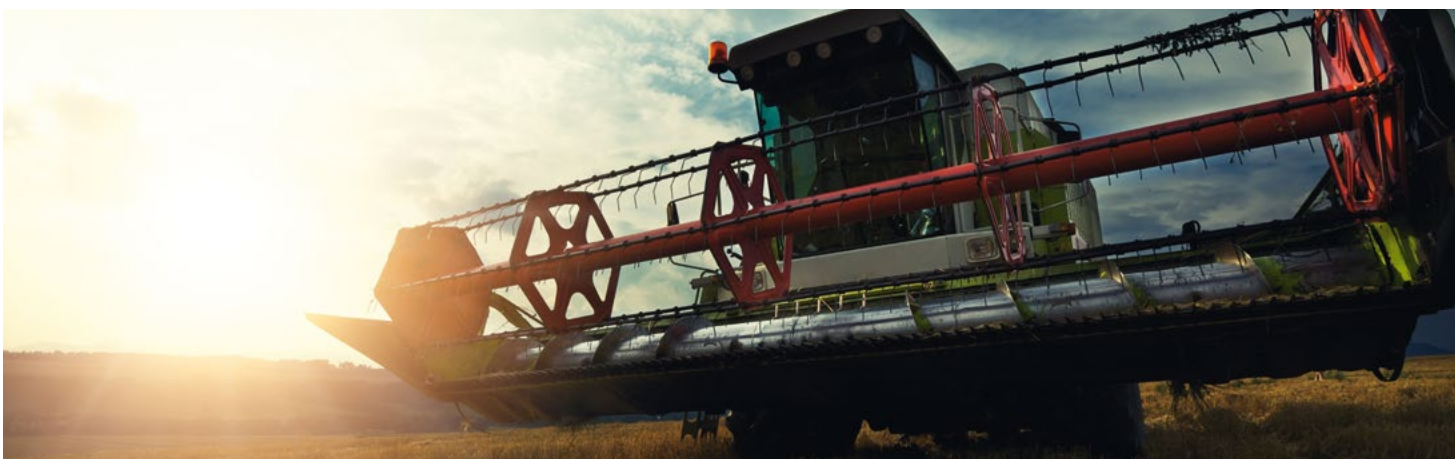

# Which system for which application?

All three tube fitting systems of the Eaton's Walterscheid Trilogy meet the requirements of demanding applications including those in Agriculture, Alternative Energy, Construction, Manufacturing, Mobile Material Handling, Offshore & Marine, Oil & Gas, and Transportation industries.

Which system is best suited for your product or project, depends on many application variables including: final in service assembly access, required pressure resistance, fluid medium, external mechanical stresses, operating environment, acquisition cost, and operating conditions. Additionally, the final in service assembly and operational environment needs consideration. Eaton's Walterscheid Trilogy is engineered to deliver the best not only in terms of performance, but also in ease of installation.

## Final in-service assembly after prefabrication (All Walterscheid systems)

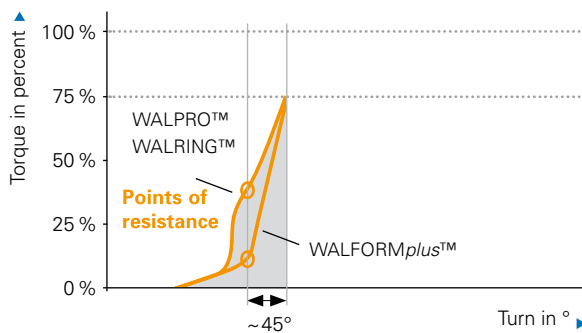

## The assembly factor

### Assembly and reshaping machines minimize the installation error and effort

Improper assembly constitutes the greatest risk of failure with any tube interface. Eaton's Walterscheid machines create the optimum installation conditions reducing the risk of failure at point of final in-service assembly. The Eaton's Walterscheid Trilogy prefabrication solutions reduce the final in-service assembly tightening movement to a maximum 1/4 of a turn, and required torque by 25%. This results in advantages for installation especially in confined spaces.

## Final in-service assembly after standard pre-assembly (WALPRO™)

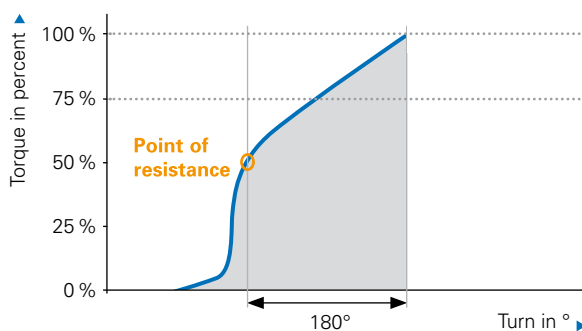

### Unmistakable pressure points indicate the end of assembly

The cold reshaping of the tube itself (WALFORMplus™), or the machine assembly of the two-edge cutting rings (WALPRO™ and WALRING™), creates a pressure point that clearly indicates the end of the assembly travel. Excessive or insufficient tightening is unlikely. This technology is engineered into each of the Eaton's Walterscheid Trilogy systems offering maximum assembly reliability.

## Complete manual assembly (WALPRO™)

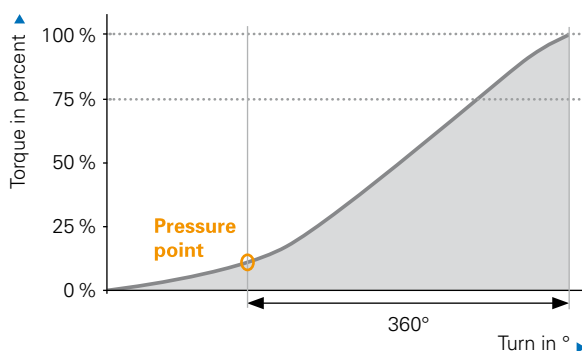

# WALPRO™ and WALRING™

Assembly with the MEG-R6 offers optimized performance and installation advantages resulting in the short tightening movement and reduced force required at final in service assembly. However, manual assembly methods can also be used for low volume production, in the event of repairs, or if no power supply is available.



## Premium

Controlled final assembly with the MEG-R6

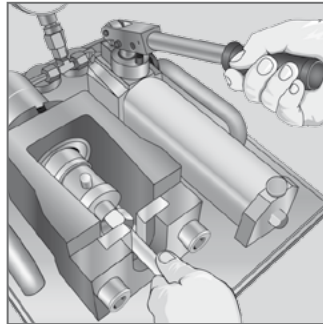

## Comfort

Assembly with the MHH-R manual pre-assembly unit

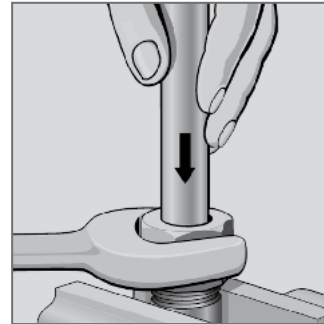

## Easy

Standard manual assembly using the pre-assembly adapter

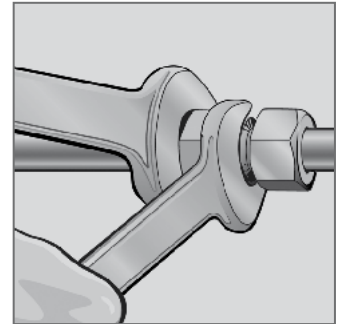

## Direct

Complete manual assembly in the fitting body



# WALFORMplus™

The WALFORMplus™ cold reshaping machine creates a profile ring in the tube itself resulting in the recognized pressure point felt during in-service assembly.

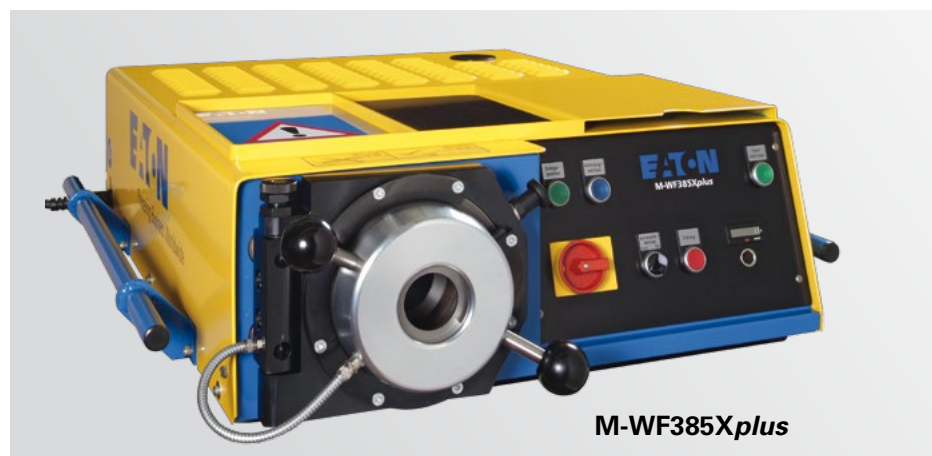

M-WF385Xplus

# The pressure resistance factor\*

## L Series up to 500 bar, S Series up to 800 bar

All the systems of the Eaton's Walterscheid Trilogy withstand high pressures and are available in the L Series and the S Series.

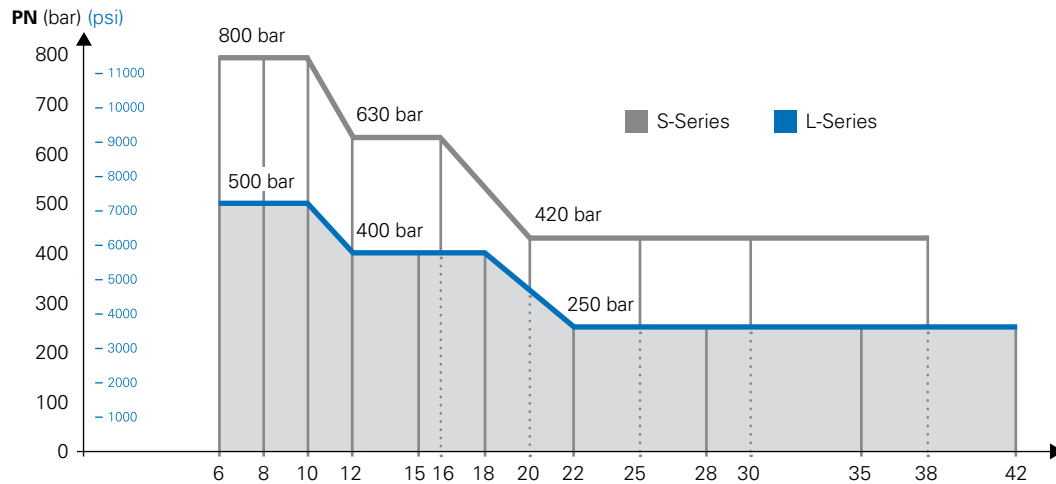

\*The mentioned nominal pressure steps are valid for carbon steel products only.

# The component factor

## Globally available DIN parts

All three systems adhere to the principle of using commonized parts, offering inventory and logistic advantages. The Eaton's Walterscheid Trilogy is based on globally available DIN/ISO bodies and nuts.

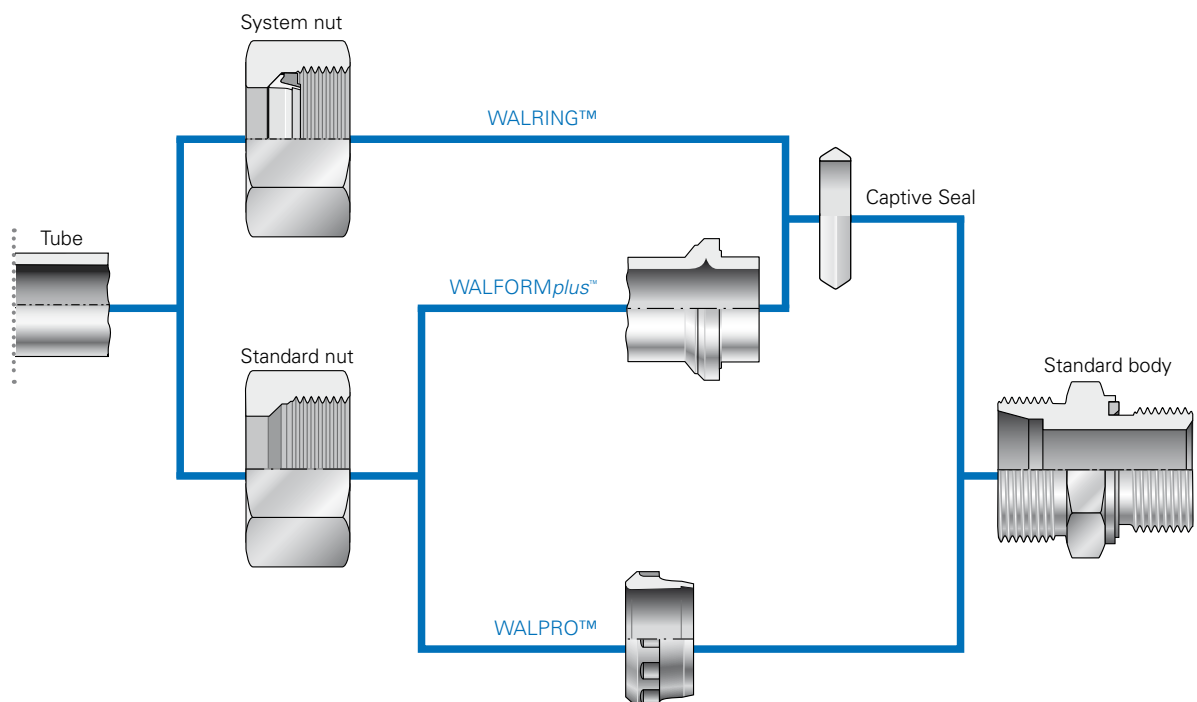

# The cost and performance factor

## Quality and reliability are priceless

Eaton's Walterscheid offers high-performance tube fittings at competitive prices – that pay for themselves by minimizing the risk of failure. The associated system cost and performance differences of the Eaton's Walterscheid Trilogy compare as follows:

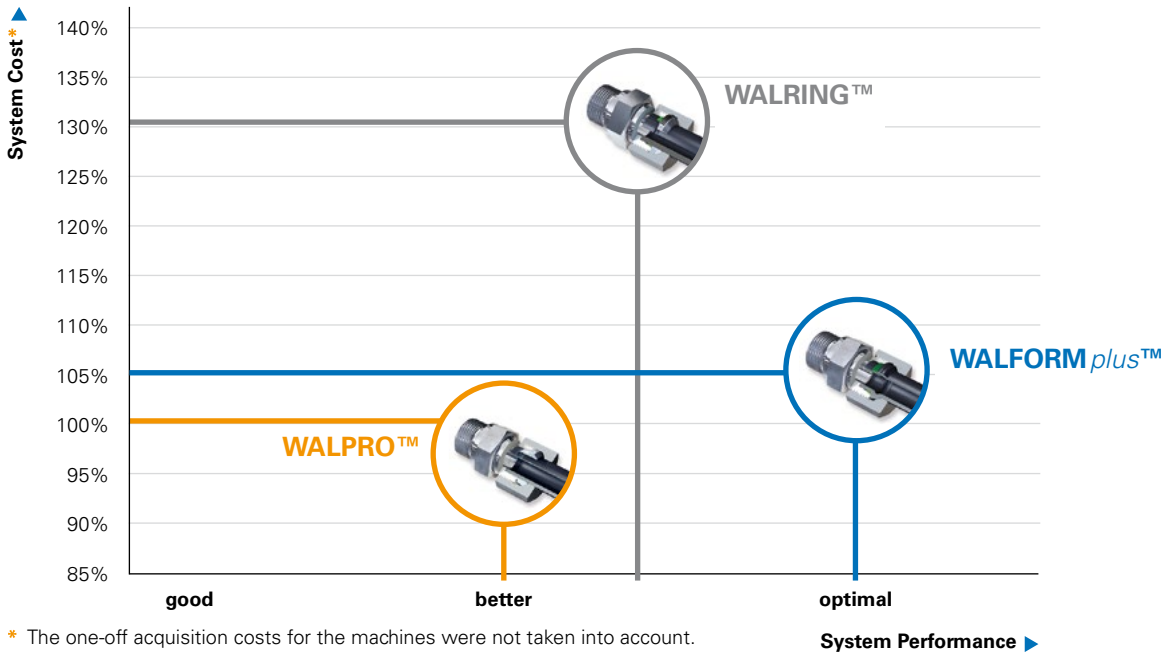

## Professional consulting services

### Our Service

- Proposals for optimizing stocking strategy
- Solutions for critical installation conditions and applications involving the most stringent safety requirements
- Answers relating to the selection and installation of tubing
- Assistance with trial tubing
- Training of assembly staff
- Multiple inventory management services
- Extensive test capabilities in our laboratory

For further information, give us a call:

**EMEA (Europe, Middle East, Africa)**

**Tel.: +49 (0)2246 100-9101**

Or send us an e-mail: [walservice@eaton.com](mailto:walservice@eaton.com)

**Americas**

**Tel.: +1 952 937 9800**

[www.eaton.com/hydraulics](http://www.eaton.com/hydraulics)

**Asia Pacific**

**Tel.: (+86 21) 5200 0099**

[www.eaton.com/hydraulics](http://www.eaton.com/hydraulics)



# The Guardian Seal™ Factor

## Nickel-free corrosion protection – durable and environment-friendly

**Guardian Seal surface plating not only guarantees excellent, durable corrosion protection, but also provides a convincing answer from the point of view of health protection and environmental compatibility.**

Guardian Seal is a special, zinc-based surface treatment that is applied by electroplating. The zinc layer is passivated by a special process, resulting in an open-pored structure. Organic micro-particles are then impregnated into this structure in an optimized immersion process adapted to the chemical system. The cross-linked polymerization of the top layer is then completed via a unique curing process. The result: a durable, highly corrosion-resistant plating surface is created.

### Characteristics

- Corrosion protection up to 360 hours to white corrosion / 720 hours to red corrosion according to VDMA 24576, K5 (exceeding SAE J514 / 96 hours to red corrosion)
- Chromium-6 free
- Nickel free
- Torque value same as Chromium-3 (also known as Hex Chrome free)
- Similar silver appearance to Chromium-3
- Global availability
- Exclusive in tube fitting market
- Industry-leading technology

### Health and Safety

- Guardian Seal contains no Nickel
- No risk of Nickel dust during assembly and handling
- No risk of contact allergies (Nickel allergies)

### Environmental Protection

- Wastewater treatment after plating requires less chemical processing compared to Zinc-Nickel
- Economical, reproducible quality
- No consumption of Nickel, in comparison to Zinc-Nickel plating (12-16% nickel content)





# Guardian Seal coating Structure

Chromium-6 free plating on Zinc base with passivation and top coat.

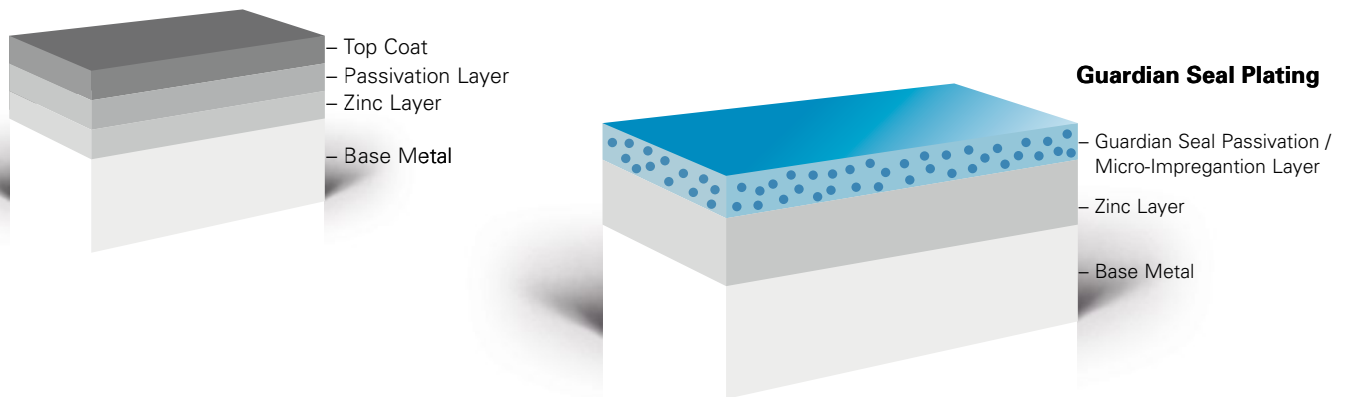

## Guardian Seal in practice:

- Guardian Seal coating is paintable with commercially available coatings. Crosscut adhesion tests according to DIN ISO 2409 are recommended.
- Guardian Seal coating is resistant to commonly used hydraulic fluids.
- Guardian Seal coating is in accordance to the EU-Old Car Directive (ELV 2000/53/EG).
- Guardian Seal coating and Chromium-3 or Zinc-Nickel plated parts can be used in the same application.
- Assembly and disassembly are unchanged compared to Chromium-3 plated Walterscheid parts.



after 360 hours



after 720 hours

## Guardian Seal coating in salt spray test

according to DIN EN ISO 9227



# The Stainless Steel Factor

## WALPRO-X™

### The Profile Ring in Stainless Steel



**Protecting man and the environment - Eaton's Walterscheid technology, also available in stainless steel.**

Corrosive media and extreme conditions of use call for special materials. WALPRO-X™ was developed specifically for use in critical, high-dependability situations. In short, wherever safety and the protection of the environment are of prime importance.

#### Tapping ends developments

WALPRO-X™ withstands up to 50% higher pressure stages than comparable tube connecting systems.

Optimized cutting angles and inherently stable cutting edges ensure efficient tapping and maximum retaining strength. Computer-optimized profiling guarantees that the tube is effectively secured.

#### Forward-looking configurations

When it comes to threads, special silver-coated AGP nuts (recommended for size 15L/12S and upwards) reduce tightening and keeping torque to a minimum. Dismantling and repeat assembly work are appreciably simplified.

#### Revolutionary assembly technology

Mechanically controlled final assembly is now also available for stainless steel.

The tightening distance is reduced to only 30° after increase in force, necessitating considerably less effort. As a result, assembly times are reduced by up to 50%.

#### Advantages at a glance

- Unique max. capacity of L-series, 400 bar nominal pressure; max. capacity of S-series, 630 bar nominal pressure
- 100% reproducible and controlled assembly via Eaton's Walterscheid final assembly machines
- Components comply with DIN EN ISO 8434-1
- In the thread area special silver-coated AGP nuts (optionally available)

#### Approvals (systematic)





## WALFORMplus™

**Design and choice of material determines success – reliable, secure and durable**



**WALFORMplus™, one of the world's most dependable tube connecting systems, available in stainless steel to meet the most demanding requirements.**

WALFORMplus™ positive-locking connecting system guarantees complete reliability, even under high static and dynamic loads. In stainless steel, it is wider than the average joint and can be used, in particular, in critical situations or where the emphasis is on safety.

### Innovative solutions

A single step in the end face of the specially shaped tube characterises the WALFORMplus™. The result: assembly that makes it easy for installers.

WALFORMplus™ offers complete sealing integrity, as a result of the proven WALFORMplus™ captive seal, the metallic seal between the threaded adapter and the patented WALFORMplus™ step.

### Easy assembly

The unique design of WALFORMplus™ provides for convenient assembly. The tightening distance and torque are considerably reduced. Completion of the assembly process is indicated by a noticeable increase in force.

### Tailor made systems

Special, silver-coated AGP nuts are also available for the threaded parts of the WALFORMplus™ system (recommended for size 15L/12S and upwards). As a result, repeat assemblies are significantly simplified.

For particularly corrosive media or high temperatures, Eaton's Walterscheid can also supply WALFORMplus™ joints in metallic sealing configurations or with alternative materials for the captive seal. Do not hesitate to contact us for advice.

### Advantages at a glance

- Unique max. capacity of L-series, 400 bar nominal pressure; max. capacity of S-series, 630 bar nominal pressure.
- Workmanship of the utmost reliability assured by failsafe provisions against faulty assembly.
- Components comply with DIN EN ISO 8434-1
- In the thread area special silver-coated AGP nuts (optionally available).
- WALFORMplus-M metallic sealing version for high temperature applications and aggressive media.
- WALFORMplus-SR-1.4571 support-ring solution for thin-walled tubes.

### Innovation



**M-WF385-EX1 according to ATEX rule Ex II 2G II B T4X**

**Eaton**  
**Hydraulics Group USA**  
14615 Lone Oak Road  
Eden Prairie, MN 55344  
USA  
Tel: +1 952 937 9800  
Fax: +1 952 294 7722  
[www.eaton.com/hydraulics](http://www.eaton.com/hydraulics)

**Eaton**  
**Hydraulics Group Europe**  
Route de la Longeraie 7  
1110 Morges  
Switzerland  
Tel: +41 (0) 21 811 4600  
Fax: +41 (0) 21 811 4601

**Eaton**  
**Hydraulics Group Asia Pacific**  
Eaton Building  
4th Floor, No. 3 Lane 280  
Linhong Rd  
Changning District  
Shanghai 200335  
China  
Tel: (+86 21) 5200 0099  
Fax: (+86 21) 5200 0400